

## Low Profile Mounts-All Attitude Vibration Isolators

Low profile mounts are compact, lightweight vibration isolators designed for the protection of sensitive equipment in severe dynamic environments. Designed to be highly adaptable to challenging applications in a wide variety of industries, they are all attitude, fail-safe and provide efficient vibration protection in all axes. They produce natural frequencies in the range of 15 — 20 Hz and are available in a selection of materials to accommodate many environmental conditions.

For general purpose applications a natural rubber version is available. These versions (VIB1101 and VIB1102) are suitable in applications where ambient temperatures range from  $-25$  to  $+180$  °F. Damping in this material is moderate resulting in maximum amplification at resonance of 10.0 under typical environmental conditions.

For industrial applications, where oil or chemical exposure is possible, a neoprene elastomer version is available. These versions (VIB2101 and VIB2102) are suitable in applications where ambient temperatures range from  $-20$  to  $+220$  °F. Damping in this material is moderate resulting in maximum amplification at resonance of 10.0 under typical environmental conditions.

For aerospace applications or where temperature extremes are anticipated, a silicone version is available. These versions (VIB3101 and VIB3102) are appropriate where temperature ranges from  $-65$  to  $+300$  °F. The silicone elastomer blend used in the construction of holder type mounts produces excellent damping characteristics resulting in a maximum amplification at resonance of 4.0 for all sizes under typical environmental conditions.

Low profile mounts are rugged and fail-safe for survival of severe dynamic inputs. They are capable of withstanding 15G 11 ms half-sine shock inputs without damage. They are available in 2 sizes with load ratings from 1 to 18 lbs.

### Features:

- Lightweight, low-profile design
- Efficiently isolates vibration in all directions
- 1:1 Axial to Radial spring rate
- Fail-safe construction

Low Profile mounts are available in two sizes:

- 101 size: 4 load ratings from 1 to 11 lb
- 102 size: 5 load ratings from 6 to 18 lb

### Applicable Military Specifications:

- MIL-STD-810

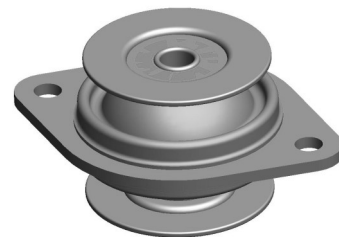

# VIB101 Series

## PRODUCT SPECIFICATIONS

Operating Temperature:

- 65 to +300 F (silicone)
- 20 to 225 F (neoprene)
- 40 TO 180 F (NR)

Maximum Transmissibility at Resonance: 4.0 (silicone)  
10.0 (neoprene)  
10.0 (NR)

Load Capacity: 1.0 – 11 lb

Axial-Radial Stiffness Ratio: 1:1

Part Weight: 1.0 oz.

Materials & Finish:

- Metal Components—Steel per ASTM A1008/  
A1011, Zinc plated per ASTM B633 Type I
- Elastomer—See table

## Performance Characteristics

Part No.	Max. Static Load (Axial)	Axial Natural Frequency	Dynamic Axial Spring Rate		Dynamic Radial Spring Rate	
	Lbs	Hz	lb/in	N/mm	lb/in	N/mm
VIB1101-1	1.0	20	41	7	38	7
VIB2101-1						
VIB3101-1						
VIB1101-2	2.0		82	14	76	14
VIB2101-2						
VIB3101-2						
VIB1101-4	4.0		164	28	151	27
VIB2101-4						
VIB3101-4						
VIB1101-11	11.0		449	79	416	74
VIB2101-11						
VIB3101-11						

\*Fn at max rated load and .036 inch DA input

To correct for loads lower than rated load use:

$$F_n = F_{nn} * \sqrt{P_r / P_a}$$

Where:

F<sub>n</sub>: Natural Frequency at actual load (Hz)

F<sub>nn</sub>: Nominal Natural Frequency (Hz)

P<sub>r</sub>: Rated load

P<sub>a</sub>: Actual load

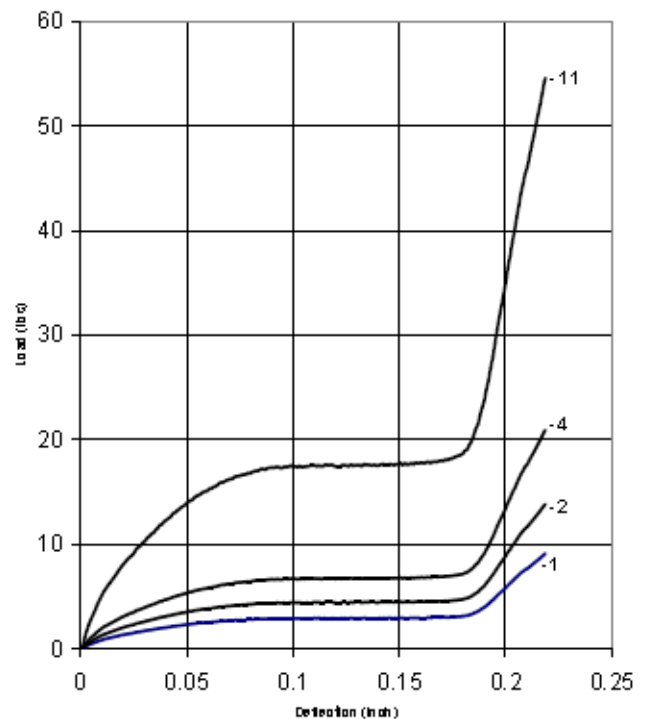
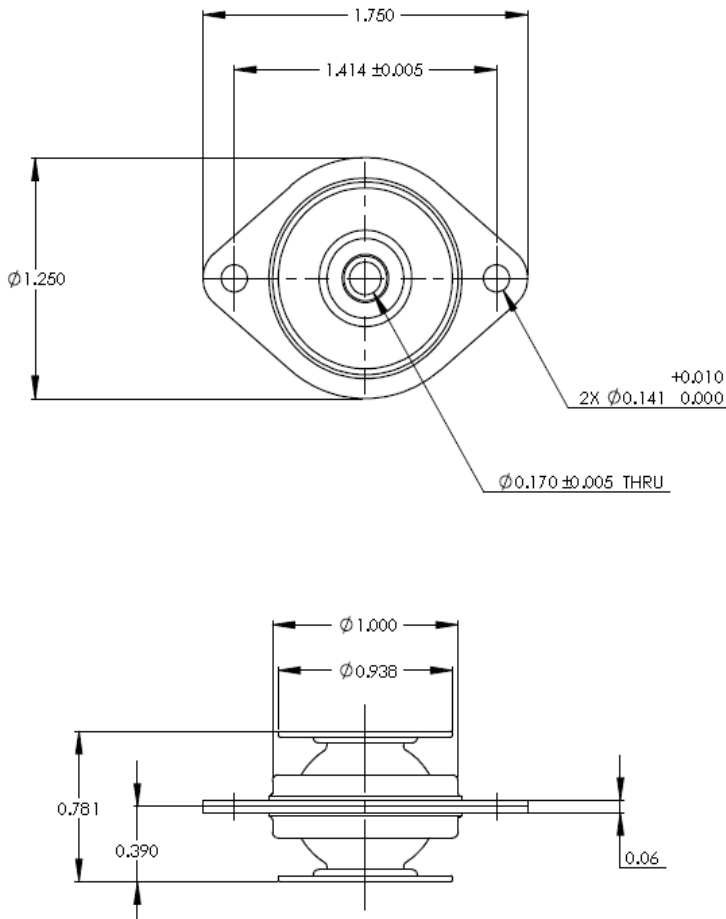

# VIB102 Series

## PRODUCT SPECIFICATIONS

Operating Temperature:

- 65 to +300 F (silicone)
- 20 to 225 F (neoprene)
- 40 TO 180 F (NR)

Maximum Transmissibility at Resonance: 4.0 (silicone)  
10.0 (neoprene)  
10.0 (NR)

Load Capacity: 4.0 – 18 lb

Axial-Radial Stiffness Ratio: 1:1

Part Weight: 1.0 oz.

Materials & Finish:

Metal Components— Steel per ASTM A1008/  
A1011, Zinc plated per ASTM B633 Type I  
Elastomer—See table

## Performance Characteristics

Part No.	Max. Static Load (Axial)	Axial Natural Frequency	Dynamic Axial Spring Rate		Dynamic Radial Spring Rate	
	Lbs		Hz	lb/in	N/mm	lb/in
VIB1101-1	4.0	20	163	29	154	27
VIB2101-1						
VIB3101-1						
VIB1101-2	6.0		245	43	232	41
VIB2101-2						
VIB3101-2						
VIB1101-4	10.0		408	72	386	68
VIB2101-4						
VIB3101-4						
VIB1101-11	18.0		735	130	695	123
VIB2101-11						
VIB3101-11						

\*Fn at max rated load and .036 inch DA input

To correct for loads lower than rated load use:

$$F_n = F_{nn} * \sqrt{P_r / P_a}$$

Where:

F<sub>n</sub>: Natural Frequency at actual load (Hz)

F<sub>nn</sub>: Nominal Natural Frequency (Hz)

P<sub>r</sub>: Rated load

P<sub>a</sub>: Actual load

